

<<< Flexi-Switching >>>

This device features Flexi-Switch™ Technology! This relay-based, true bypass switching style allows you to simultaneously use momentary and latching-style switching.

- For standard latching operation, tap the footswitch once to activate the effect and then tap again to bypass.
- For momentary operation, hold the footswitch down for as long as you'd like to use the effect. Once you release the switch, the effect will be bypassed.

Since the switching is relay-based, it requires power to pass signal.

<<< Power Requirements >>>

- Current Draw: 68mA
- This device take a standard 9 volt DC power supply with a 2.1mm negative center barrel. We always recommend pedal-specific, transformer-isolated wall-wart power supplies or multiple isolated-output supplies. Pedals will make extra noise if there is ripple or unclean power. Switching-type power supplies, daisy chains and non-pedal specific power supplies do not filter dirty power as well and let through unwanted noise. **DO NOT RUN AT HIGHER VOLTAGES!**

<<< Tech Specs >>>

- Input Impedance: 50K Ohm
- Output Impedance: <1K Ohm

<<< Warranty >>>

This device has a limited lifetime warranty. If it breaks, we will fix it. Should you encounter any issues, please email info@earthquakerdevices.com.



www.earthquakerdevices.com

©2018 EarthQuaker Devices LLC

Spatial Delivery™



OPERATION MANUAL

Welcome to your brand new Spatial Delivery™! The Spatial Delivery is an oddball, a voltage controlled envelope filter that allows you to step outside the universe of funk while reinforcing your secret love affair with auto-wah. It has 3 modes: **Up Sweep**, **Down Sweep** and **Sample and Hold**. With **Range (1)**, **Resonance (3)** and **Filter (4)** controls you can get super emphasized filter sweeps in the **Up** and **Down** modes. The **Range (1)**, in combination with pick attack, controls the sensitivity and reaction time of the envelope and thus the width of the frequency sweep. The higher the **Range** and harder the attack equals a faster reaction time and higher frequency sweep and vice versa. Reign in the controls a bit, add your favorite overdrive/fuzz after the Spatial Delivery and you've got a real nice resonant, cut-through-the-mix lead tone. Crank the controls back up and you're a neo-bedroom rock god. In the **Sample and Hold** mode the filter is controlled by random voltage and the **Range** controls the speed. Add a sub octave into the mix (before or after) and you've just created a deep fried space droid computer freak-out. The filter can be cross faded between high pass (counterclockwise), band pass (center) and low pass (clockwise) for a wide variety of voices. The **Resonance** control goes from zero to the brink of oscillation and adds more body and ring to the filter voice. We recommend placing the Spatial Delivery first in your signal chain. However, due to its envelope control, experimenting with pairing and signal chain placement can take the potential of the Spatial Delivery even further. Each Spatial Delivery is hand made bit by damn bit in silver studded Akron Ohio.

<<< Controls >>>



- 1 Range:** Adjusts the sensitivity of the envelope in **Up** and **Down** mode. In **Sample and Hold** mode, this controls the speed.
- 2 Mode Toggle:** This toggles between **Upward Sweep**, **Downward Sweep** or **Sample and Hold**.
- 3 Resonance:** This is the filter feedback control, it adds more body and ring to the filter voice.
- 4 Filter:** This crossfades between high pass and low pass filters and allows you to get everything in between. High pass is fully counterclockwise, low pass is full clockwise and center is band pass. This is much more useful than a simple switch because it allows you to blend the filters for different sounds!

<<< Suggested Settings >>>

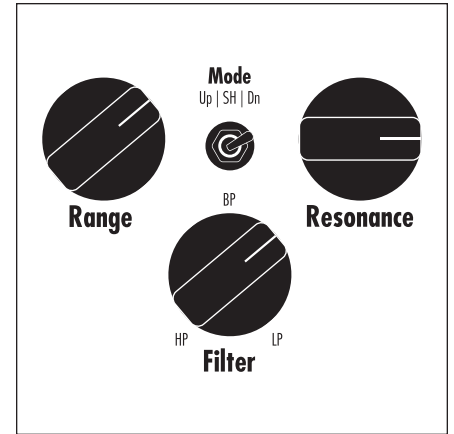
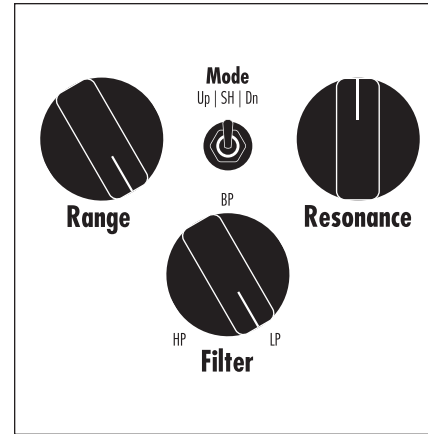

Modular Synthesizer

Create urgent and futuristic sequences to traject your music into the cosmos. Make chords feel like apreggiated time passages.

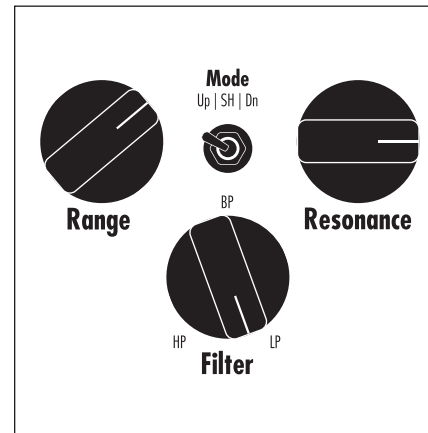

Neptune

Create the backdrop of space craters opening and closing on distant galaxy planets.

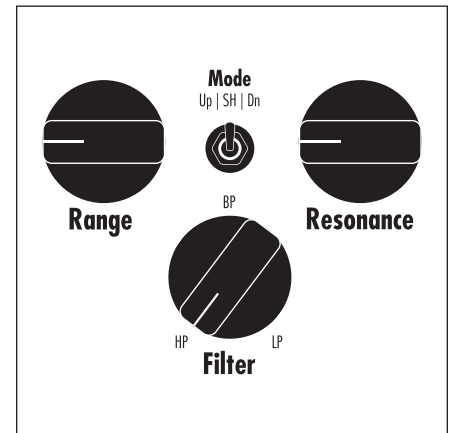

Sassy as Funk

Grab your favorite dominant 7th chord and don't fight the feelin'.

Slow Space Song

I went to outer space once... I could never find my way back... Can you hear me earthlings?... Anyone out there?...